

## **DZR Commissioning Set**



## **Flow Data and Installation Instructions**

## Technical Data

The Albion ART 27 is a fixed orifice metering station used to measure the flow passing through it, which can be used close coupled to an ART 26 double regulating valve to form a commissioning set.

### Flow Coefficient

The flow rate can be calculated using the  $K_v$  value and a measured signal.

$$K_v = \frac{Q \cdot 36}{\sqrt{\Delta P}} \quad K_{vs} = \frac{Q \cdot 36}{\sqrt{\Delta P_s}}$$

where  $K_v$  &  $K_{vs}$  = flow coefficient (m<sup>3</sup>/hr at 1 bar differential)

$Q$  = flow rate (l/s)

$\Delta P$  = headloss attributable to valve (kPa)

$\Delta P_s$  = differential pressure across tapplings (signal) (kPa)

### $K_{vs}$ Values

Size	½"UUL	½"UL	½"L	½"M
$K_{vs}$	0.103	0.234	0.473	0.976

Size	½"	¾"	1"	1¼"	1½"	2"
$K_{vs}$	1.8	4.1	7.5	16.6	23.0	47.4

### Pressure Loss

The pressure loss across a metering station is less than signal differential pressure indicated on the flow charts. The pressure loss is obtained by multiplying the pressure signal by the pressure recovery factors given in the table.

This applies to when the metering station is used in a stand alone application or close coupled to a double regulating valve.

### Pressure Recovery Factors

Size	½"UUL	½"UL	½"L	½"M
Factor	1.00	0.97	0.87	0.83

Size	½"	¾"	1"	1¼"	1½"	2"
Factor	0.67	0.5	0.5	0.5	0.5	0.4

## Technical Data

### Pressure Loss

The pressure losses for the ART 26 double regulating valves are given on the individual flow charts along with the corresponding Kv values at the various positions open.

### Installation

Metering stations must always be installed with a minimum of 5 pipe diameters of straight pipe, without intrusion, upstream of the metering station.

Downstream of the metering station a minimum of 2 pipe diameters of straight pipe are required.

When close coupled to an Albion ART 26 double regulating valves only the straight pipe upstream of the metering station is required.

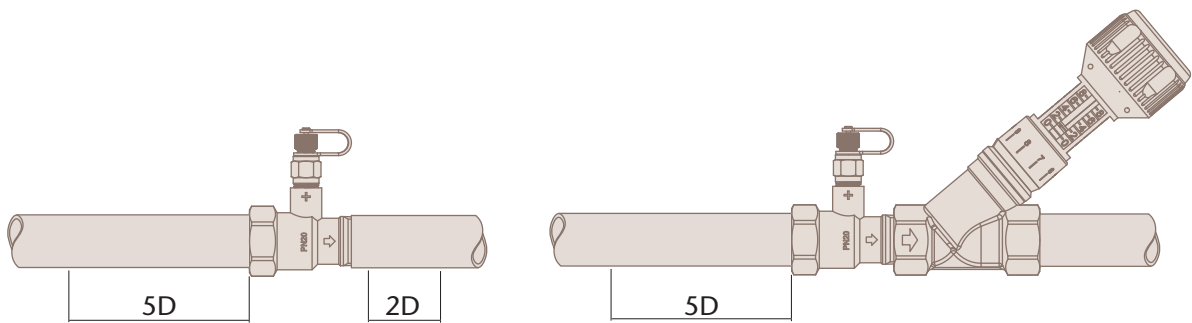

### Sizing

Once the required flow rate has been calculated, the size of the metering station can be determined based on the following:

The minimum signal at the design flow rate of 1 kPa.

For minimum pressure loss, a maximum signal of 4.7 kPa, which corresponds to the maximum differential pressure range of a fluorocarbon manometer.

### Pressure Equipment Directive

Under the Pressure Equipment Directive (PED) these metering stations and double regulating valves have been specified for Group 2 Liquids i.e. non-hazardous

Sizes ½" to 2" are classified as SEP (Sound Engineering Practice)

## 1/2" ART 27UUL DZR Metering Station

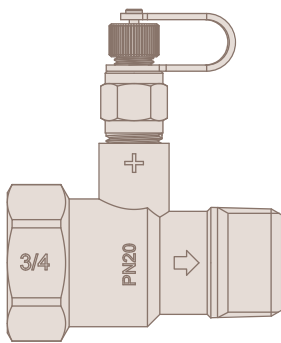
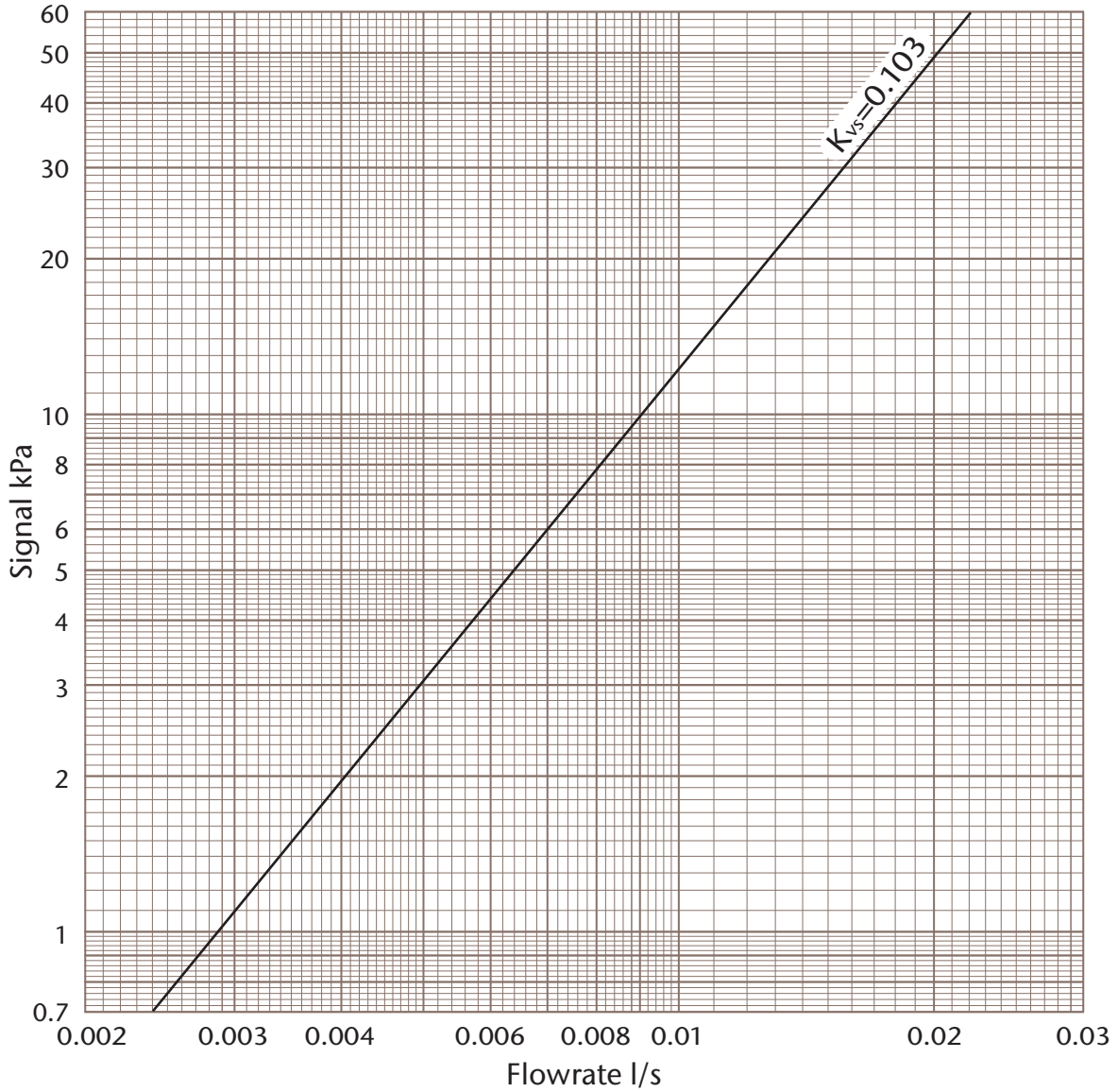

### Signal / Flowrate

Chart used to determine flowrate from signal measured across orifice

$$Q = \frac{K_{vs} \sqrt{\Delta p}}{36}$$

Where

Q = Flowrate            l/s

$\Delta p$  = Signal            kPa

$K_{vs}$  = Signal Co-efficient

## 1/2" ART 27UL DZR Metering Station

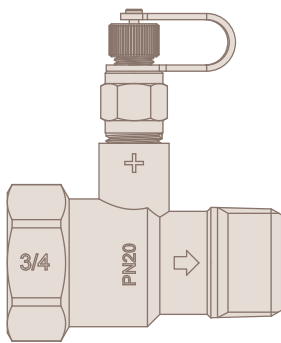
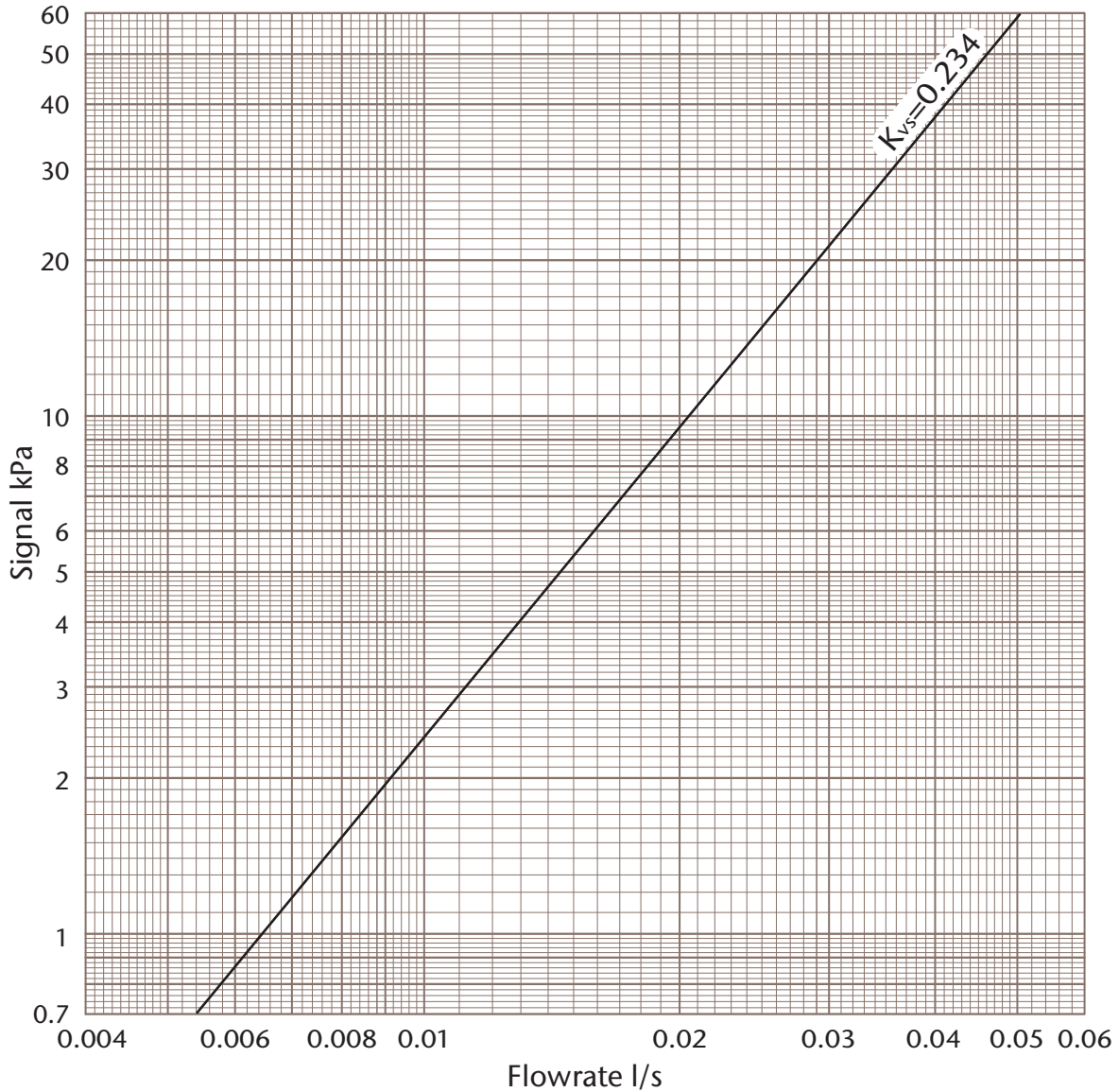

### Signal / Flowrate

Chart used to determine flowrate from signal measured across orifice

$$Q = \frac{K_{vs} \sqrt{\Delta p}}{36}$$

Where

Q = Flowrate            l/s

$\Delta p$  = Signal            kPa

$K_{vs}$  = Signal Co-efficient

## 1/2" ART 27L DZR Metering Station

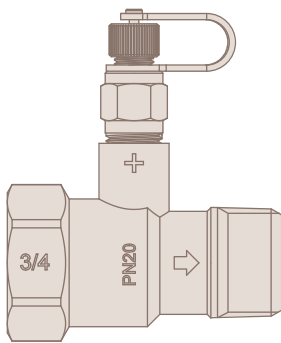
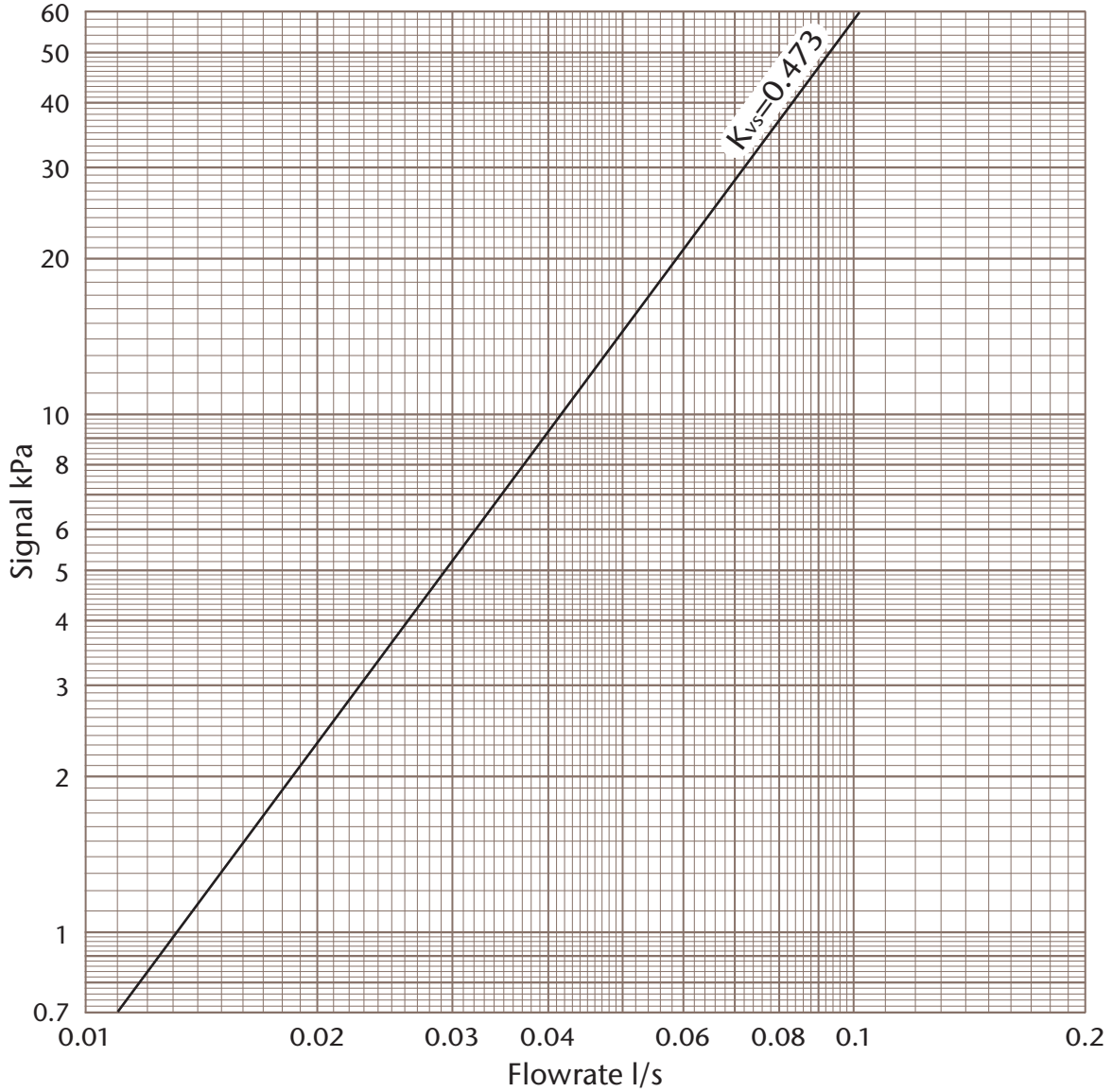

### Signal / Flowrate

Chart used to determine flowrate from signal measured across orifice

$$Q = \frac{K_{vs} \sqrt{\Delta p}}{36}$$

Where

Q = Flowrate            l/s

$\Delta p$  = Signal            kPa

$K_{vs}$  = Signal Co-efficient

## 1/2" ART 27M DZR Metering Station

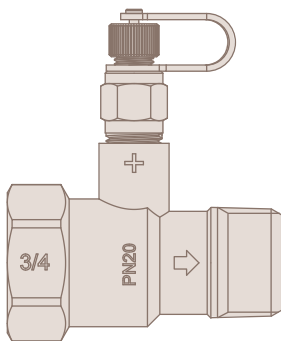
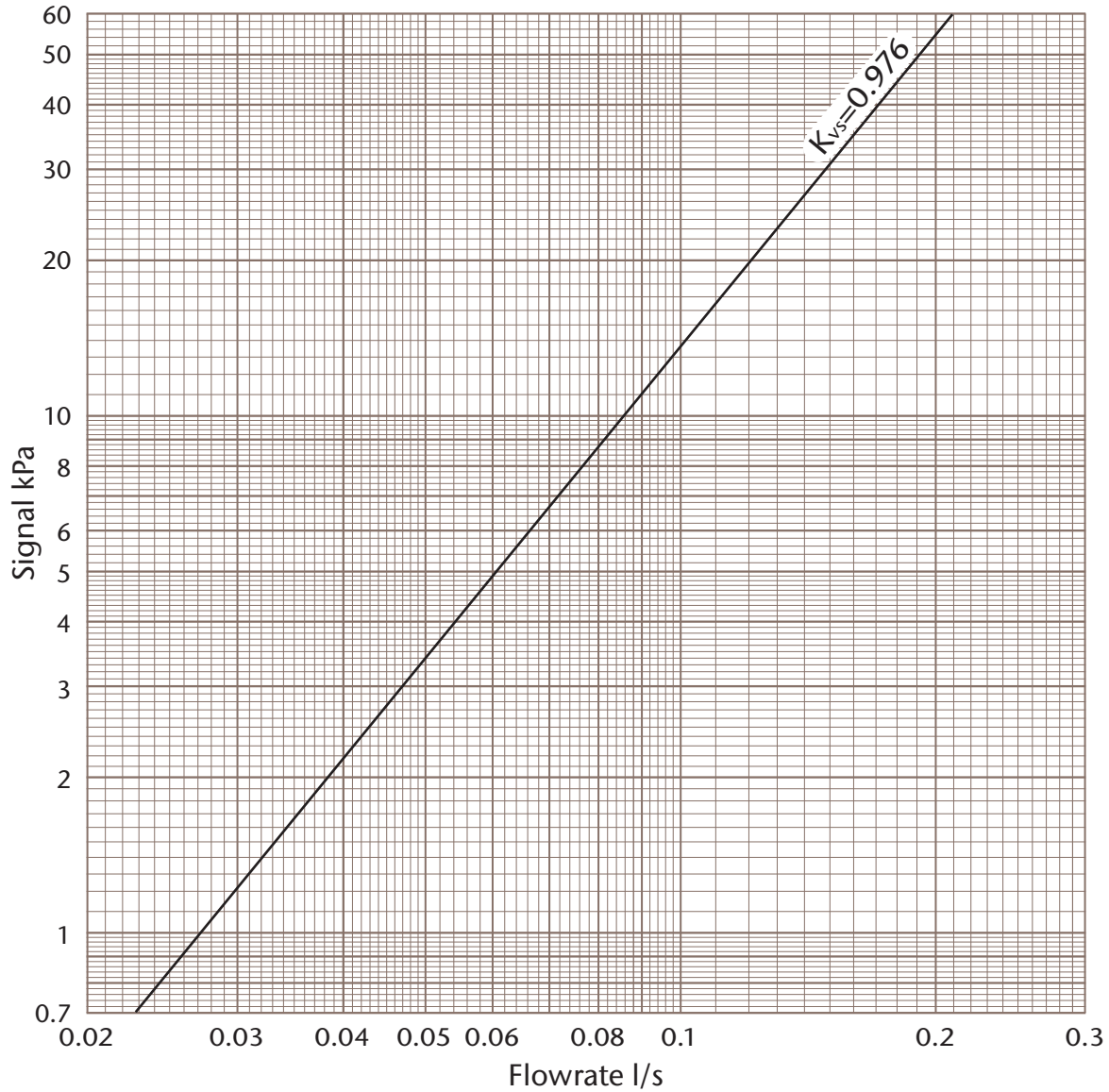

### Signal / Flowrate

Chart used to determine flowrate from signal measured across orifice

$$Q = \frac{K_{vs} \sqrt{\Delta p}}{36}$$

Where

Q = Flowrate            l/s

$\Delta p$  = Signal            kPa

$K_{vs}$  = Signal Co-efficient

## 1/2" ART 26L DZR Double Regulating Valve

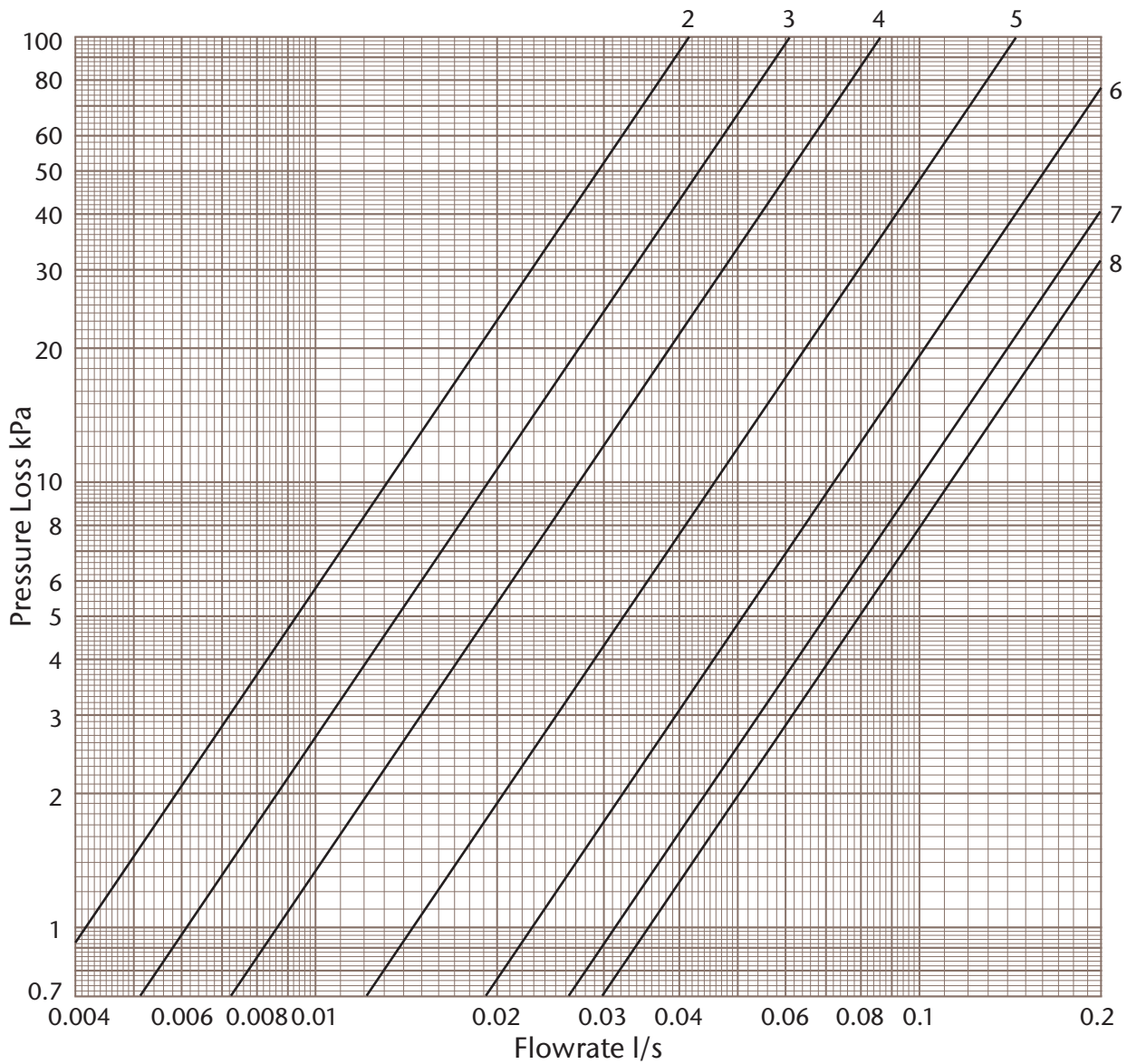

Position	2	3	4	5	6	7	8
K <sub>v</sub>	0.15	0.22	0.31	0.52	0.83	1.13	1.28

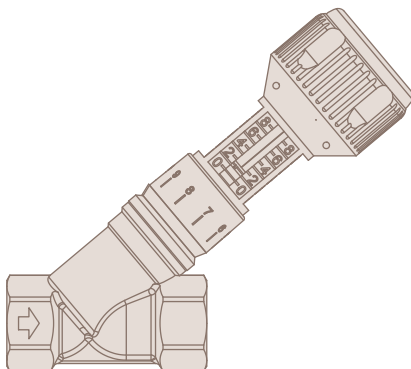

### Pressure Loss / Flowrate

Chart used to determine flowrate from signal measured across orifice

$$Q = \frac{K_v \sqrt{\Delta p}}{36}$$

Where

Q = Flowrate l/s

Δp = Pressure Loss kPa

K<sub>v</sub> = Pressure Loss Co-efficient



## 1/2" ART 27 DZR Metering Station

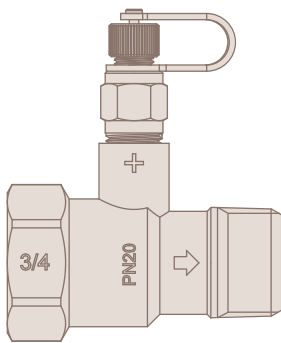
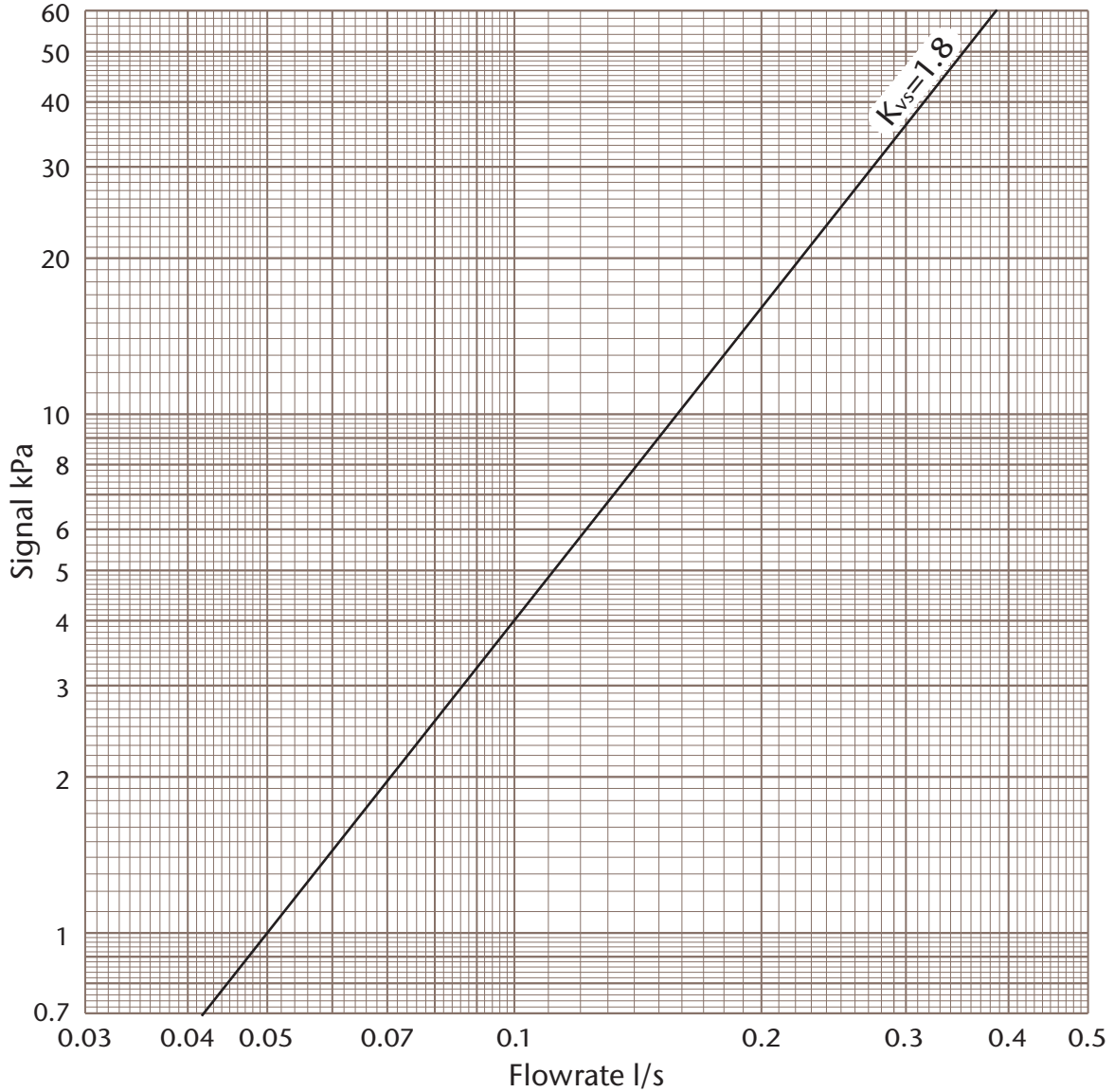

### Signal / Flowrate

Chart used to determine flowrate from signal measured across orifice

$$Q = \frac{K_{vs} \sqrt{\Delta p}}{36}$$

Where

Q = Flowrate            l/s

$\Delta p$  = Signal            kPa

$K_{vs}$  = Signal Co-efficient

## 1/2" ART 26 DZR Double Regulating Valve

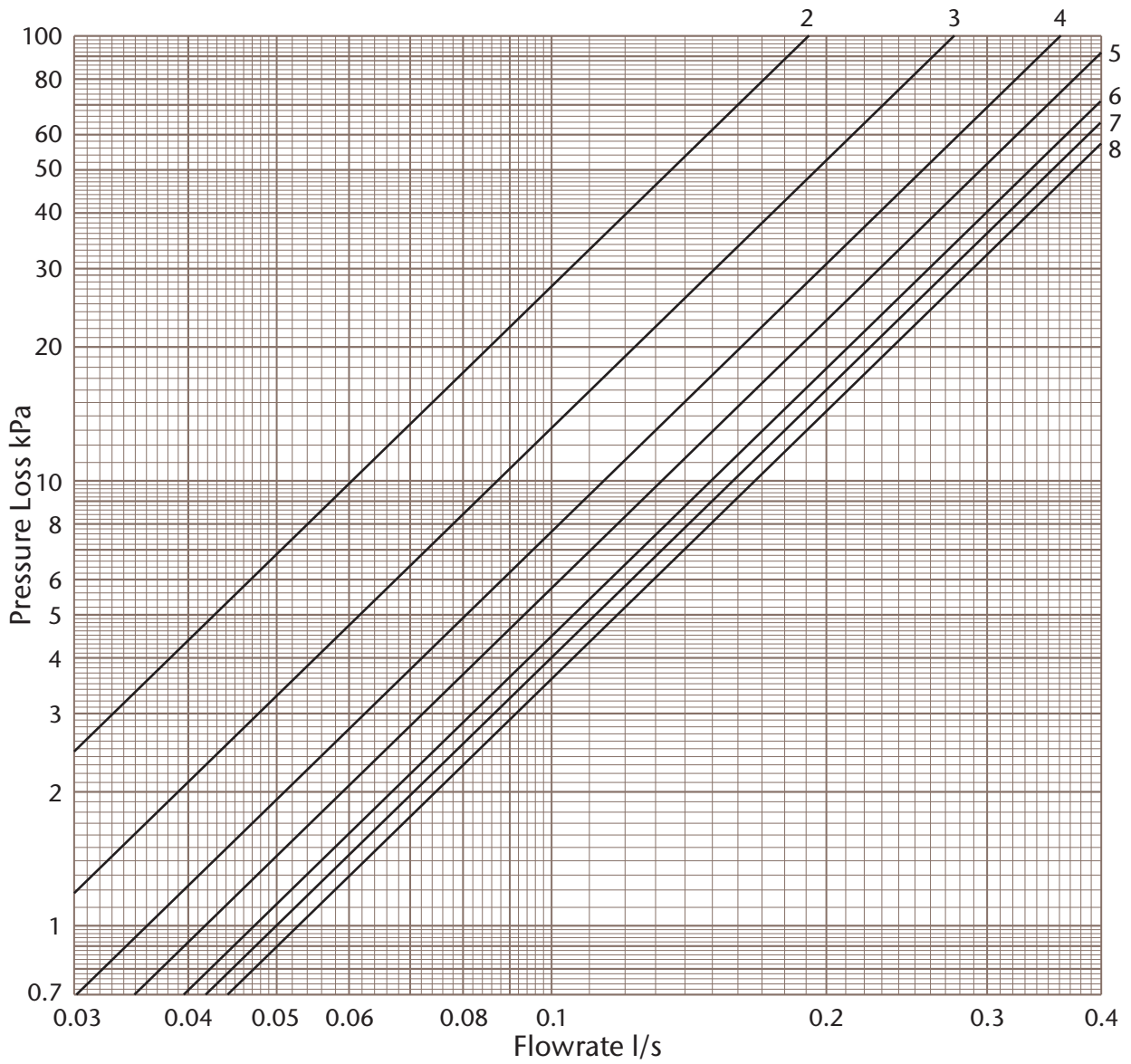

Position	2	3	4	5	6	7	8
K <sub>v</sub>	0.69	0.99	1.3	1.5	1.7	1.8	1.9

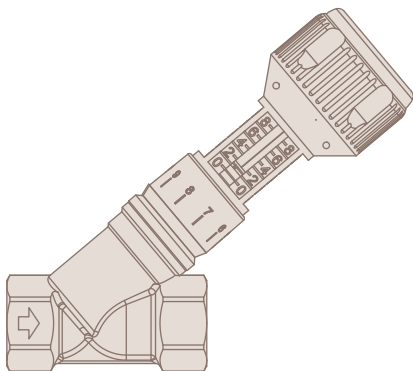

### Pressure Loss / Flowrate

Chart used to determine flowrate from signal measured across orifice

$$Q = \frac{K_v \sqrt{\Delta p}}{36}$$

Where

Q = Flowrate l/s

Δp = Pressure Loss kPa

K<sub>v</sub> = Pressure Loss Co-efficient

## 3/4" ART 27 DZR Metering Station

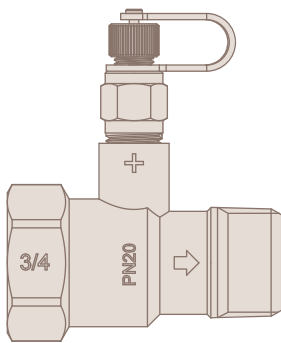
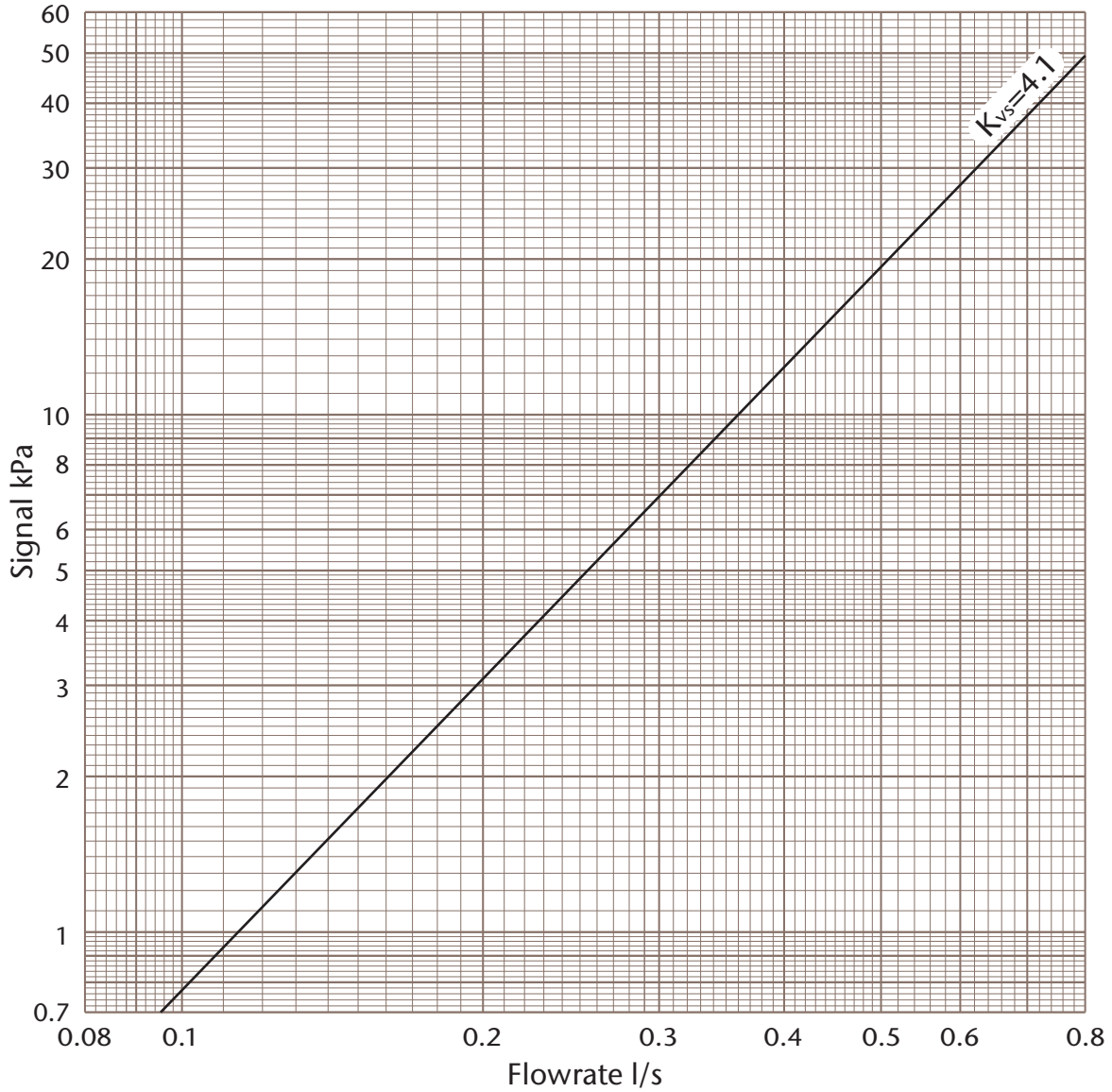

### Signal / Flowrate

Chart used to determine flowrate from signal measured across orifice

$$Q = \frac{K_{vs} \sqrt{\Delta p}}{36}$$

Where

Q = Flowrate            l/s

$\Delta p$  = Signal            kPa

$K_{vs}$  = Signal Co-efficient

## 3/4" ART 26 DZR Double Regulating Valve

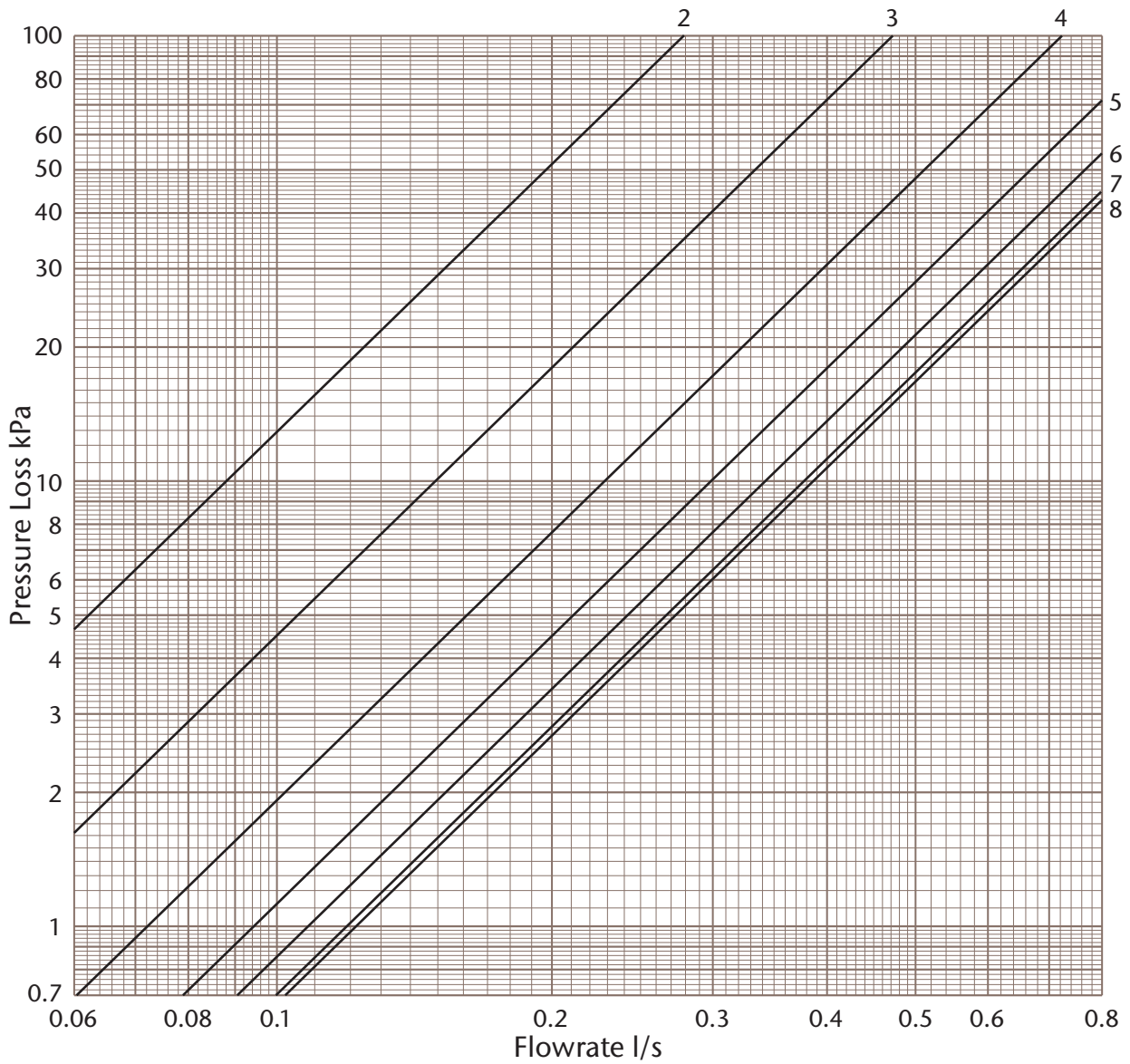

Position	2	3	4	5	6	7	8
Kv	1.0	1.7	2.6	3.4	3.9	4.3	4.4

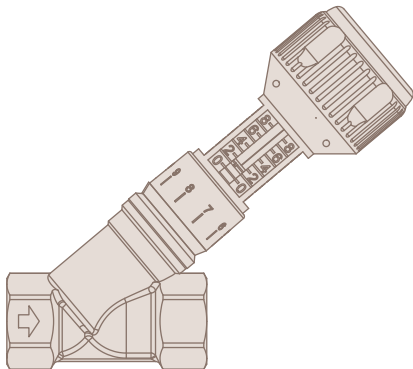

### Pressure Loss / Flowrate

Chart used to determine flowrate from signal measured across orifice

$$Q = \frac{K_v \sqrt{\Delta p}}{36}$$

Where

Q = Flowrate l/s

$\Delta p$  = Pressure Loss kPa

K<sub>v</sub> = Pressure Loss Co-efficient

## 1" ART 27 DZR Metering Station

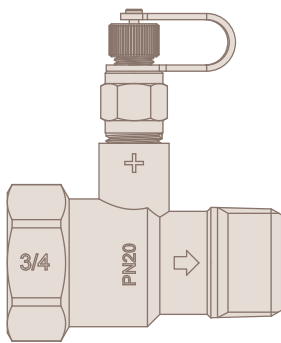
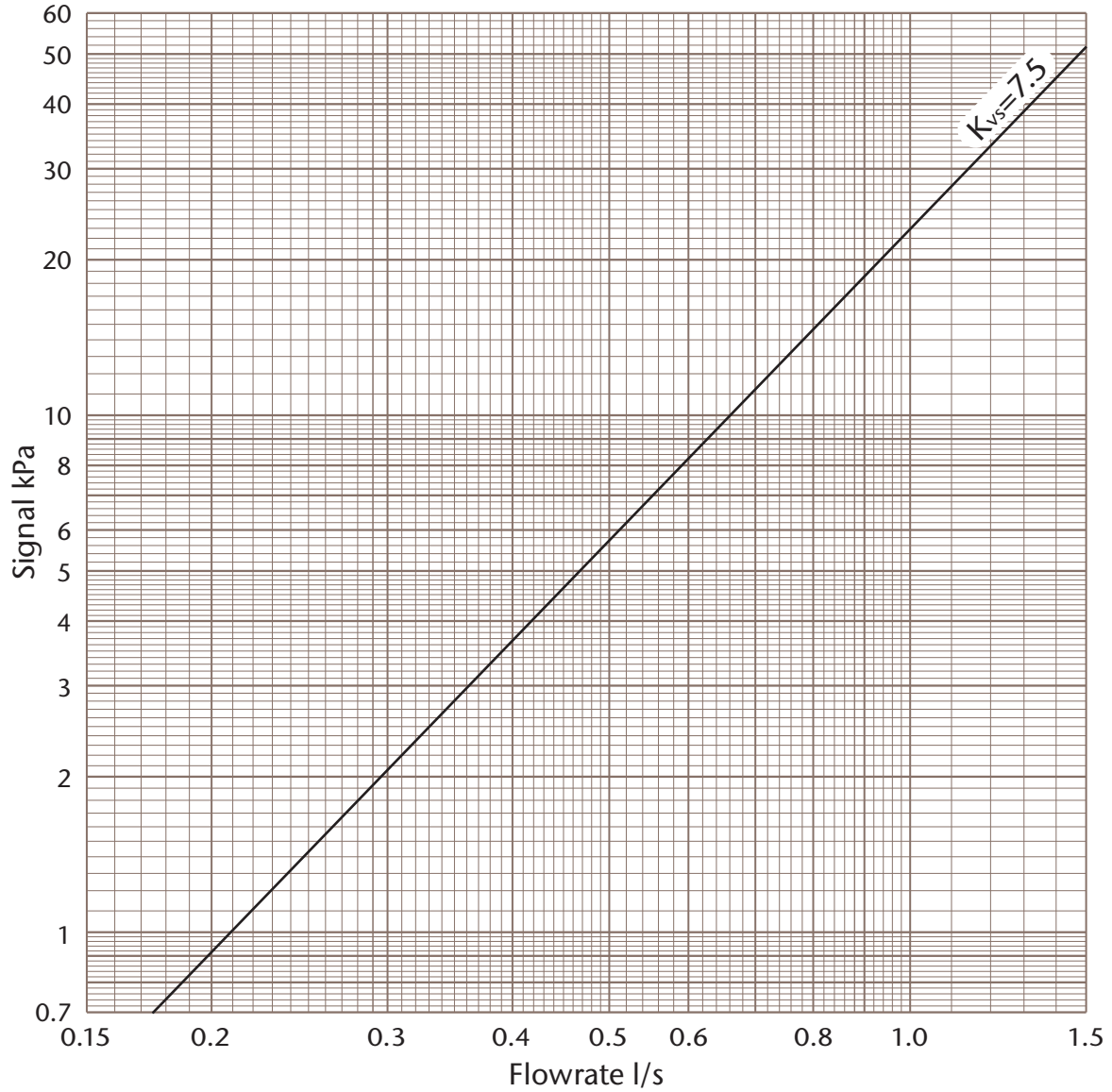

### Signal / Flowrate

Chart used to determine flowrate from signal measured across orifice

$$Q = \frac{K_{vs} \sqrt{\Delta p}}{36}$$

Where

Q = Flowrate            l/s

$\Delta p$  = Signal            kPa

$K_{vs}$  = Signal Co-efficient

## 1" ART 26 DZR Double Regulating Valve

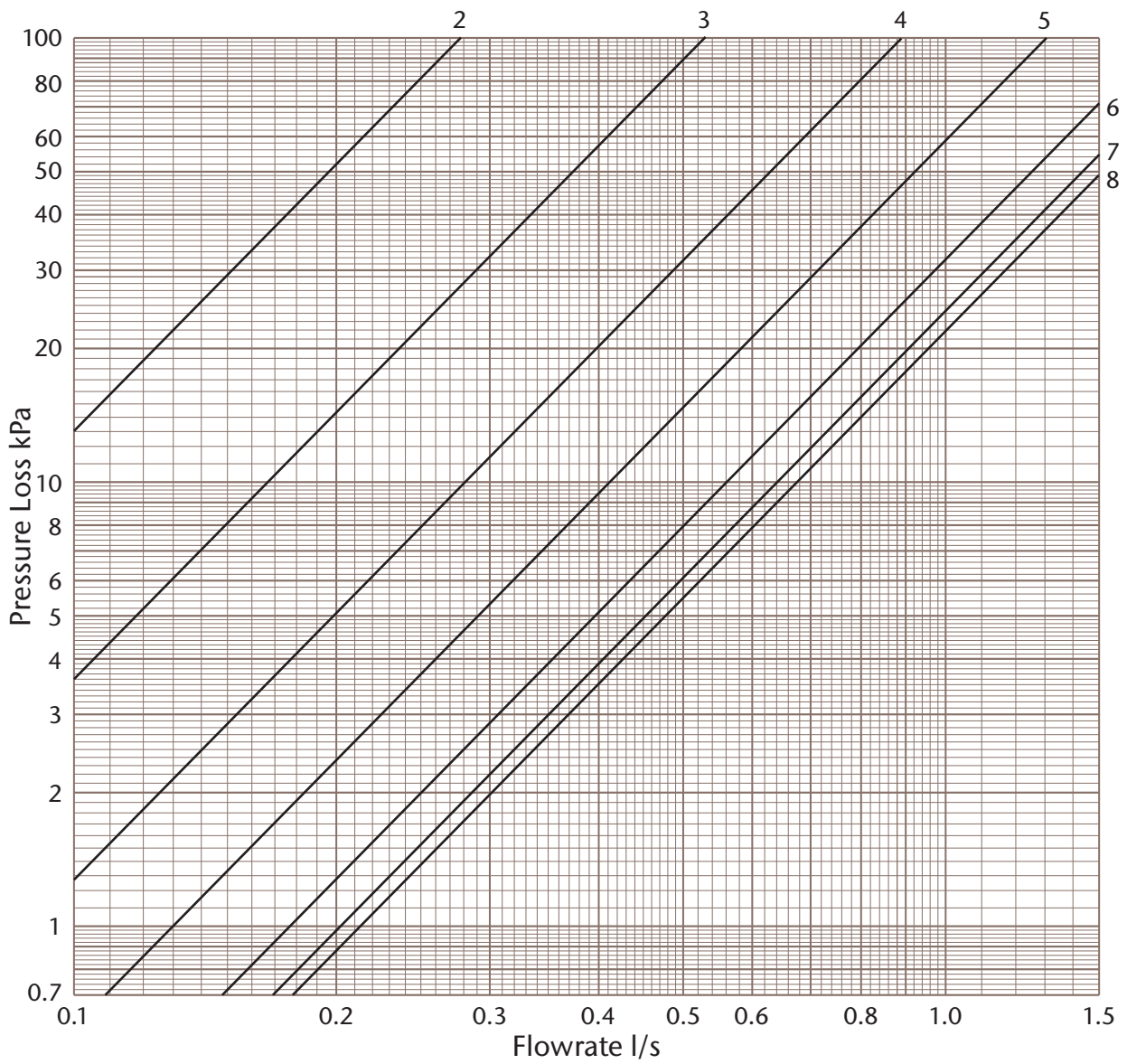

Position	2	3	4	5	6	7	8
Kv	1.0	1.9	3.2	4.7	6.4	7.3	7.7

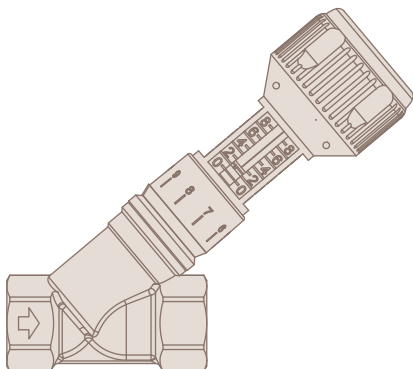

### Pressure Loss / Flowrate

Chart used to determine flowrate from signal measured across orifice

$$Q = \frac{K_v \sqrt{\Delta p}}{36}$$

Where

Q = Flowrate l/s

$\Delta p$  = Pressure Loss kPa

Kv = Pressure Loss Co-efficient

## 1 1/4" ART 27 DZR Metering Station

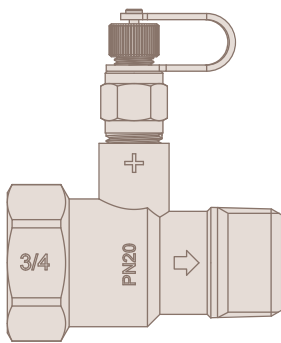
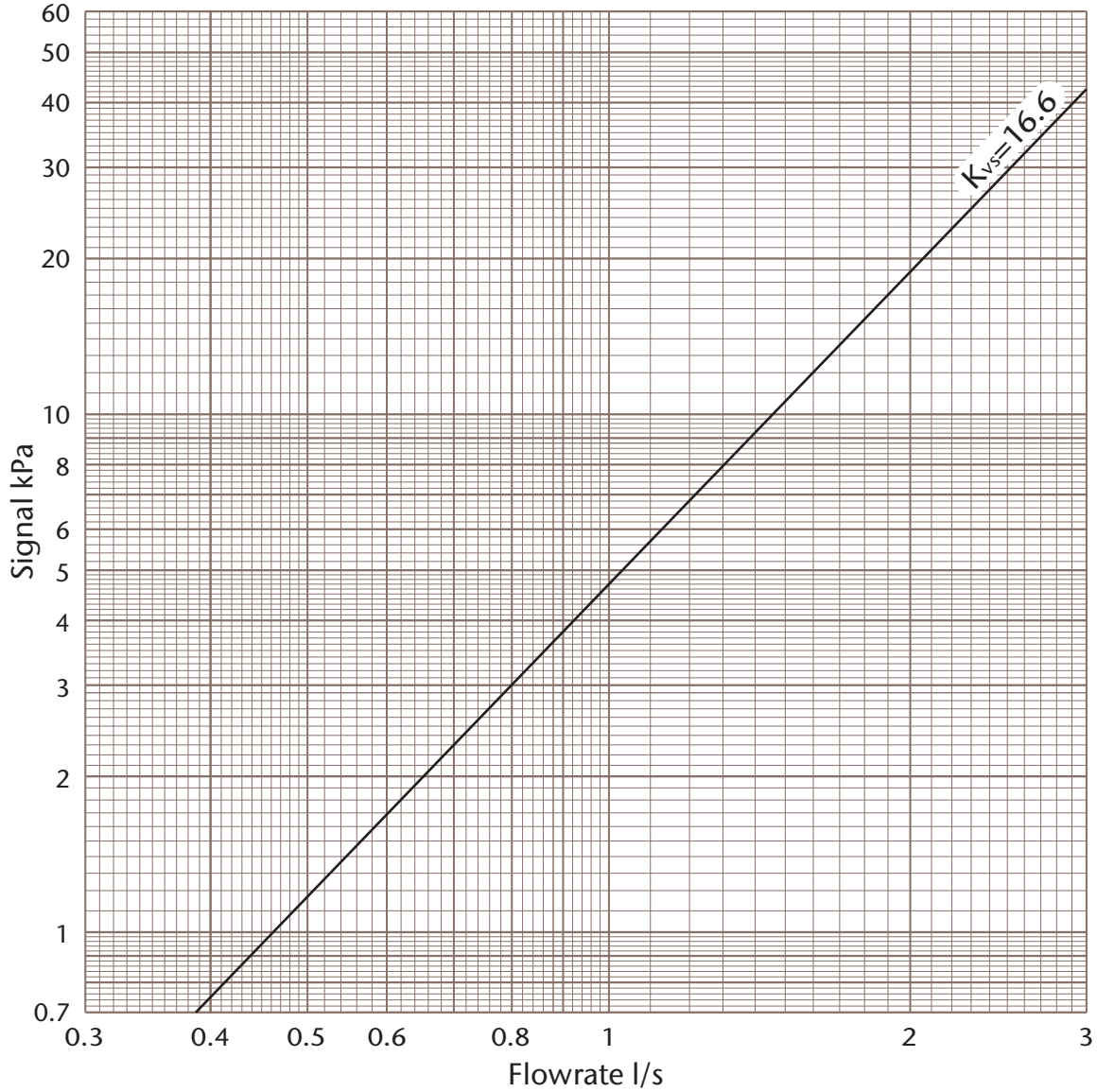

### Signal / Flowrate

Chart used to determine flowrate from signal measured across orifice

$$Q = \frac{K_{vs} \sqrt{\Delta p}}{36}$$

Where

Q = Flowrate            l/s

$\Delta p$  = Signal            kPa

$K_{vs}$  = Signal Co-efficient



## 1 1/4" ART 26 DZR Double Regulating Valve

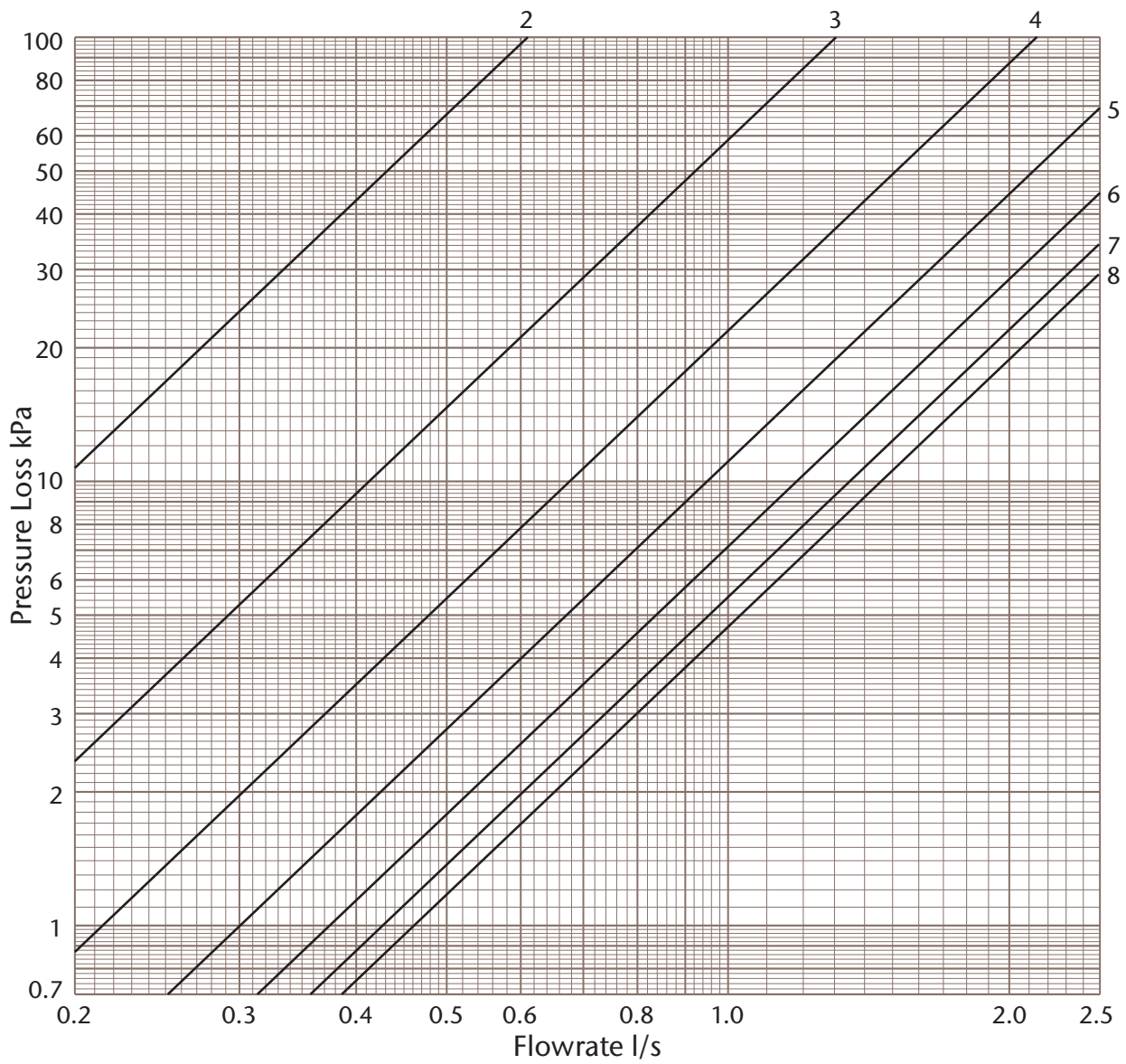

Position	2	3	4	5	6	7	8
Kv	2.2	4.7	7.7	10.8	13.5	15.4	16.6

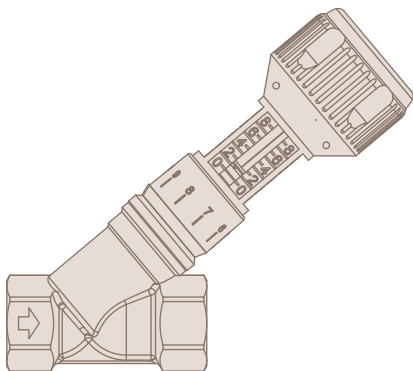

### Pressure Loss / Flowrate

Chart used to determine flowrate from signal measured across orifice

$$Q = \frac{K_v \sqrt{\Delta p}}{36}$$

Where

Q = Flowrate l/s

$\Delta p$  = Pressure Loss kPa

Kv = Pressure Loss Co-efficient



## 1 1/2" ART 27 DZR Metering Station

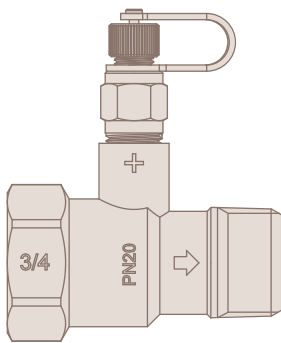
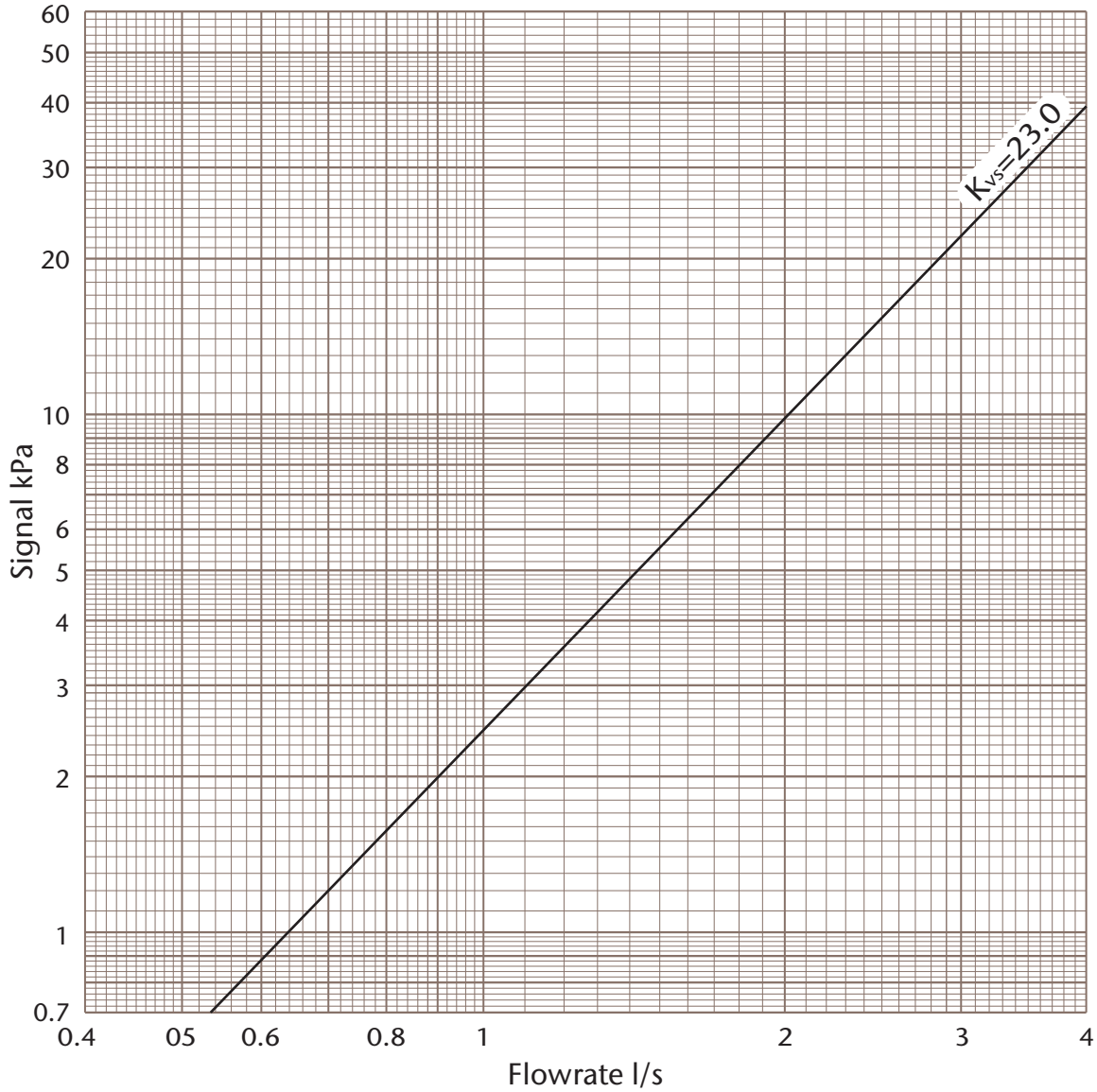

### Signal / Flowrate

Chart used to determine flowrate from signal measured across orifice

$$Q = \frac{K_{vs} \sqrt{\Delta p}}{36}$$

Where

Q = Flowrate            l/s

$\Delta p$  = Signal            kPa

$K_{vs}$  = Signal Co-efficient

## 1 1/2" ART 26 DZR Double Regulating Valve

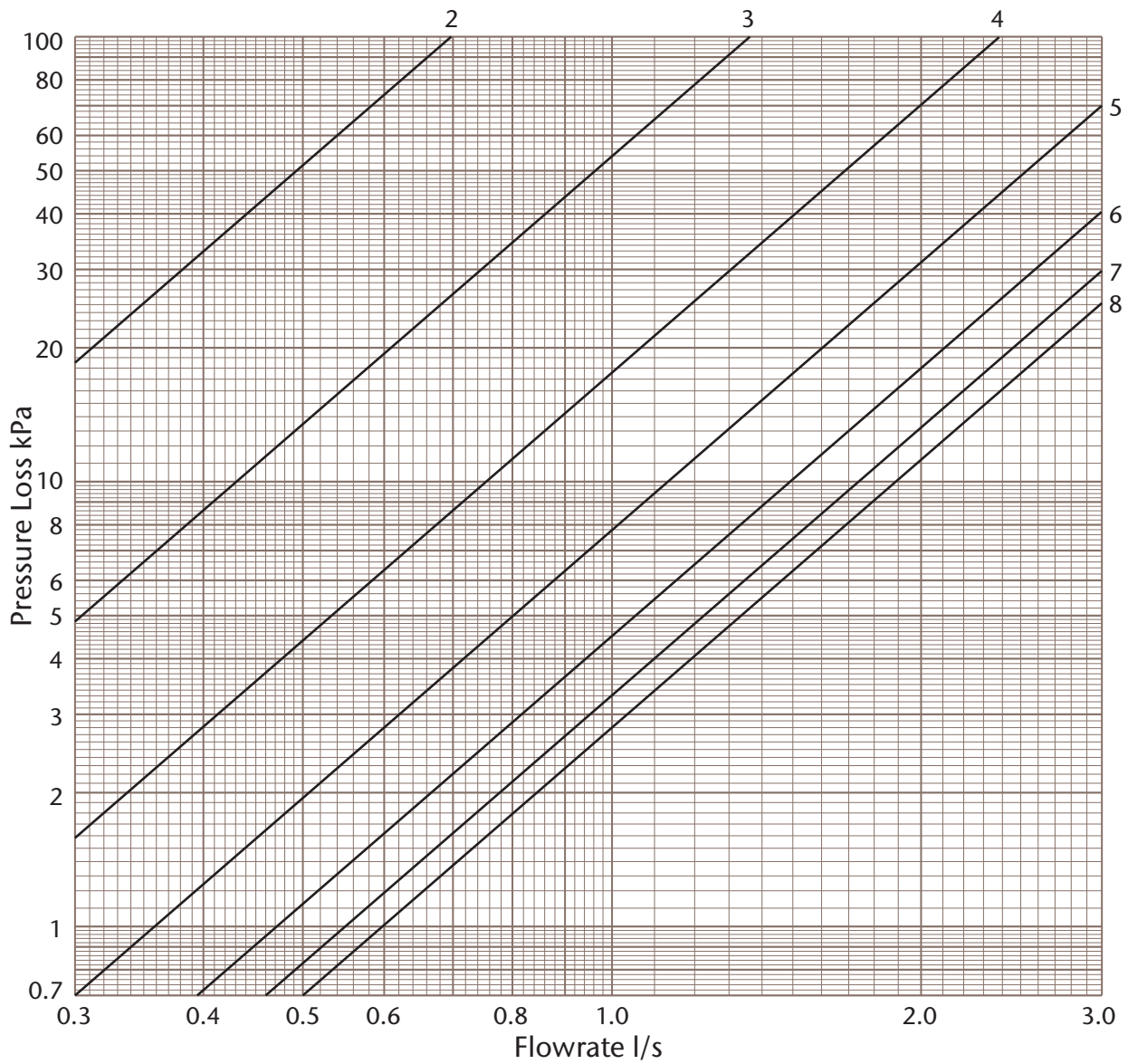

Position	2	3	4	5	6	7	8
Kv	2.5	4.9	8.6	12.9	17.0	19.8	21.5

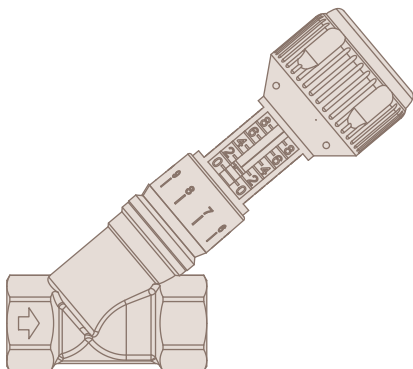

### Pressure Loss / Flowrate

Chart used to determine flowrate from signal measured across orifice

$$Q = \frac{K_v \sqrt{\Delta p}}{36}$$

Where

Q = Flowrate l/s

$\Delta p$  = Pressure Loss kPa

Kv = Pressure Loss Co-efficient

## 2" ART 27 DZR Metering Station

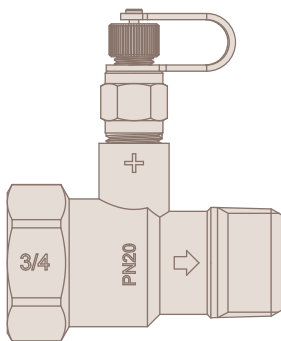
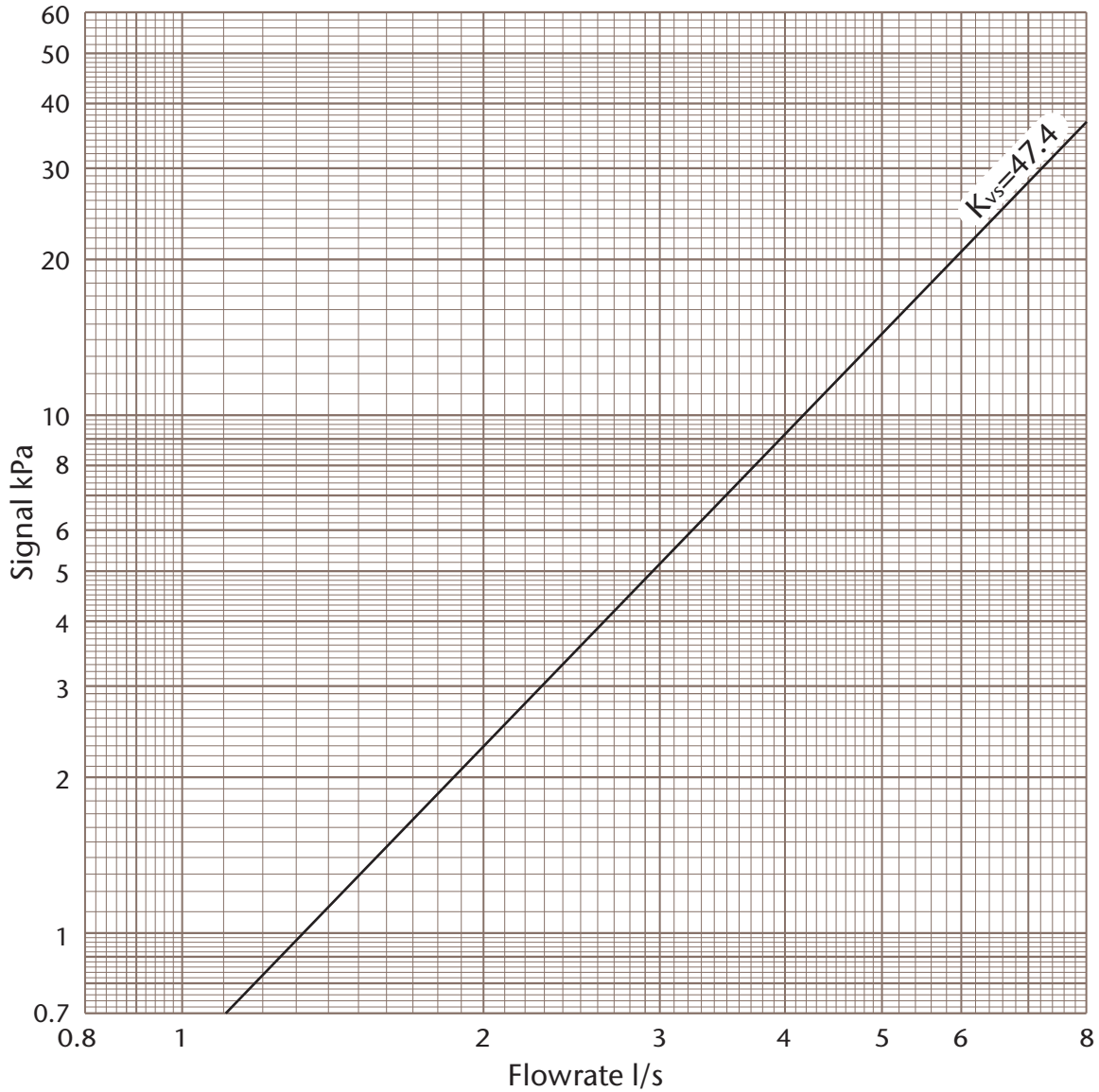

### Signal / Flowrate

Chart used to determine flowrate from signal measured across orifice

$$Q = \frac{K_{vs} \sqrt{\Delta p}}{36}$$

Where

Q = Flowrate            l/s

$\Delta p$  = Signal            kPa

$K_{vs}$  = Signal Co-efficient

## 2" ART 26 DZR Double Regulating Valve

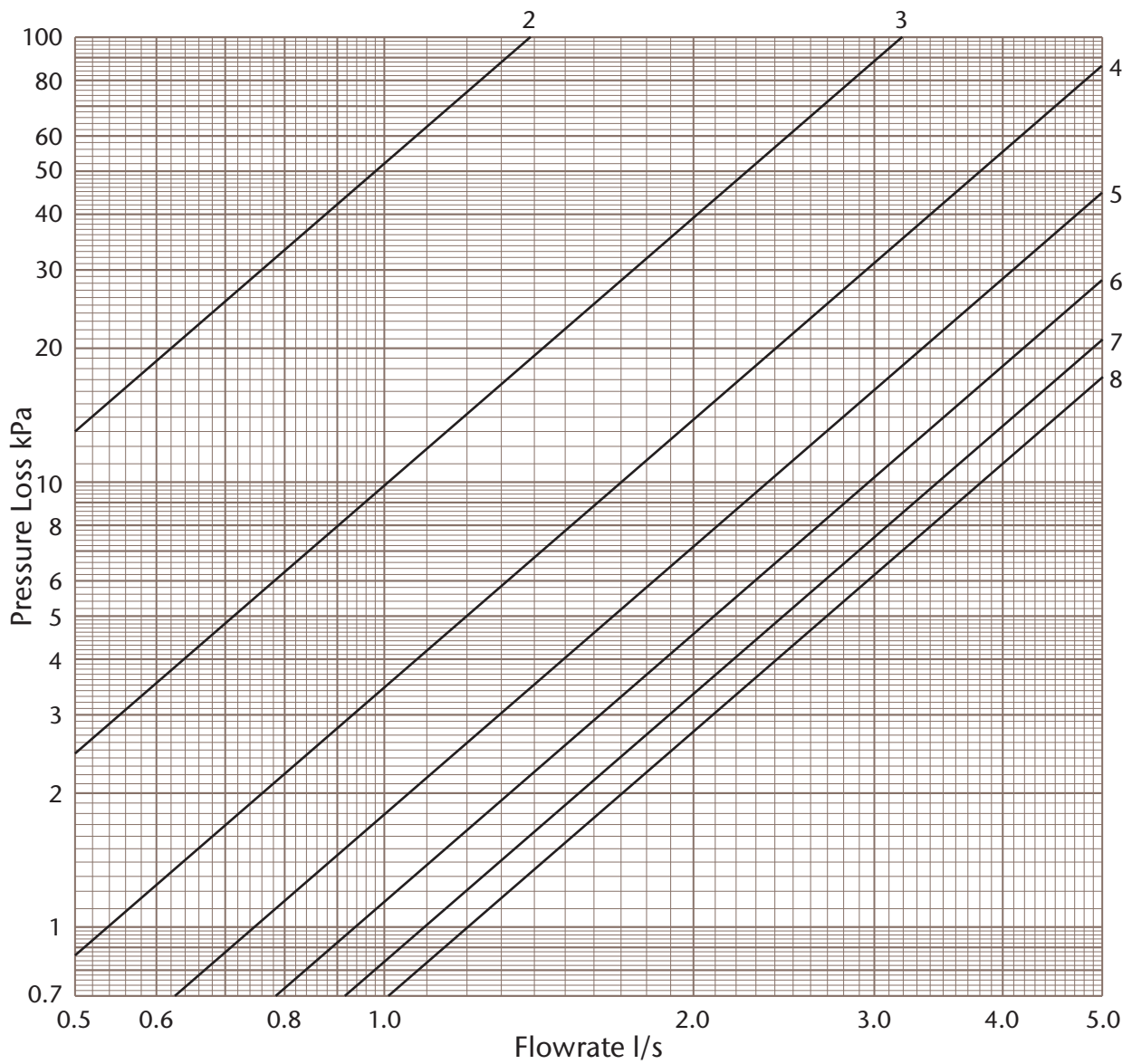

Position	2	3	4	5	6	7	8
Kv	5.0	11.5	19.4	26.9	33.7	39.5	43.6

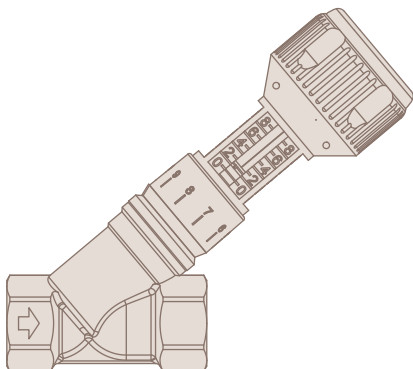

### Pressure Loss / Flowrate

Chart used to determine flowrate from signal measured across orifice

$$Q = \frac{K_v \sqrt{\Delta p}}{36}$$

Where

Q = Flowrate l/s

$\Delta p$  = Pressure Loss kPa

Kv = Pressure Loss Co-efficient